

Operating and Installation Instructions

Electronic Control Box Type: 2300

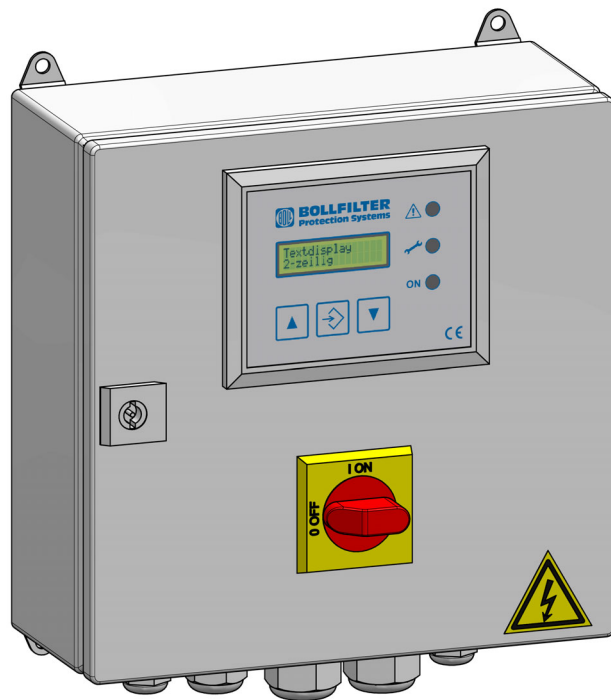

Siemensstraße 10 - 14
50170 Kerpen
Germany
www.bollfilter.de

Date	Version	Language	Order no.	Item No.
06.2019	001	en	-	-

NOTE:
Print document on both sides

Translation of the original operating instructions

Table of Contents

1	Basic safety instructions for the electronic control box	5
2	Technical data of the control box and control cabinet components	7
2.1	Power components	7
2.1.1	Supply	7
2.1.2	Motor actuation	7
2.1.3	Voltage supply	7
2.1.4	Fuses	7
2.2	Control circuit board inputs/outputs	8
2.2.1	Optocoupler inputs (E1-E5), terminals 31 - 40	8
2.2.2	Analogue input 4-20 mA, terminals 41 -42	8
2.2.3	Live relay outputs	8
2.2.4	Floating relay outputs	8
3	Operation	9
3.1	Device functions and control flow	9
3.1.1	Main switch operating feedback contact	10
3.1.2	Control voltage monitoring	10
3.1.3	Motor fault	10
3.1.4	Differential pressure too high, flushing oil treatment cartridge alarm	11
3.1.5	DP too high backflushing filter ($\Delta P100\%$)	11
3.1.6	Operating hours counter	11
3.1.7	Error memory	11
3.1.8	Differential pressure transmitter 4-20 mA	11
3.1.9	DPT-Alarm	11
3.1.10	Z key (additional functions display)	12
3.1.11	Multiple flushing	12
3.1.12	DP-Alarm (flushing frequency monitoring)	12
3.1.13	Message A4 "Flushing Active"	12
3.1.14	Time delay differential pressure $\Delta P75\%$ and $\Delta P100\%$	12
3.1.15	Function Remote On/Off (remote switching)	13
3.1.16	Initialisation with filter type 6.18/6.19/6.44	13
3.1.17	Limit switch alarm	13
3.2	"Operation" mode display	13
3.3	Text messages	14
3.3.1	Text display after switching on	14
3.3.2	Text display in "operation" mode	14
3.3.3	Alarm messages	15
3.4	Adjustment and operation	16
3.4.1	Setting level - parameter selection and view	16
3.4.2	Setting level - parameter change and storage	16
3.4.3	Jump back to the operating level	17
3.5	Parameter list and description	18
3.5.1	P0 Filter type	18
3.5.2	P1 multiple flushing	18
3.5.3	P2 time-dependent backflush triggering	18
3.5.4	P3 time-dependent backflush triggering	18
3.5.5	P4 Backflushing time	19
3.5.6	P5 Filling time	19
3.5.7	P6 After-blowing time	19
3.5.8	P7 Delay time cartridge alarm	20

3.5.9	P8 DP-Alarm (flushing frequency monitoring)	20
3.5.10	P9 Motor fault.	20
3.5.11	P10 Backflushing time	21
3.5.12	P11 Language	21
3.5.13	P12 Testcode	22
3.5.14	P14 Pressure equalisation time	22
3.5.15	P15 DP-Select "Differential pressure switch or differential pressure transmitter"	23
3.5.15.1	"MAX DPT" setting	24
3.5.15.2	Setting "DP flushing"	24
3.5.15.3	Setting "DP too high"	24
3.5.16	P16 Differential pressure delay time	24
3.5.16.1	Time delay setting "Differential pressure flushing $\Delta P75\%$ "	25
3.5.16.2	Time delay setting "Differential pressure too high $\Delta P100\%$ "	25
3.5.17	P17 Alarm relay A2, A3, A4 (configurable alarm outputs)	25
4	Control box description, function and setting values	27
4.1	Control box of type 6.18 / 6.19 / 6.44 and aquaBoll®6.18.3	27
4.1.1	Setting values filter type 6.18/6.19/6.44 and aquaBoll®6.18.3	28
4.2	Control boxes of type 6.21/6.22/6.23 / 6.24	29
4.2.1	Filter type setting values 6.21/6.22	30
4.3	Control boxes of type 6.60	32
4.4	Control boxes of type 6.61	35
4.5	Control boxes of type 6.62	38
4.6	Control boxes of type 6.64	40
4.7	Control boxes of type 6.72	43
5	Remedying faults	47
5.1	Trouble shooting	47

1 Basic safety instructions for the electronic control box



DANGER!

Risk of accidents due to improper installation

A failure of the device resulting from improper installation of the electronic control box or the connected equipment could cause severe personal injury or even fatal injury. Therefore, in addition to the general safety rules for equipment in industrial power installations, comply with the following points in particular:

- The installation of the control box should only be performed by qualified specialist staff in accordance with the conditions of IEC 364 and DIN VDE 0105 for electrical equipment.
 - All applicable laws, conditions, regulations and instructions relating to the installation of electrical equipment must be observed in relation to the installation location.
 - Settings for IP00 protection class devices without covers must only be made by authorised specialist staff, with the devices switched off and in compliance with the local safety and accident prevention regulations.
 - The control box may only be operated in the permitted area of use.
-

2 Technical data of the control box and control cabinet components

2.1 Power components

2.1.1 Supply

Supply L1-L2-L3 directly to the 4-pole main switch - Q1 (T1-T2-T3)

2.1.2 Motor actuation

Motor connection U-V-W direct at the motor contactor - K1 (2-4-6)

2.1.3 Voltage supply

Primary voltages	0 - 220 V, 380 V, 400 V, 440 V, 500 V, 550 V
Secondary voltages	
0 V AC - 230 V AC	Valve voltage 230 V AC
0 V AC - 115 V AC	Valve voltage 115 V AC
0 V DC - 24 V DC	Valve voltage 24 V DC
0 V AC - 20 V AC	Control circuit board supply voltage

2.1.4 Fuses

Fuses in the control cabinet

F1 to F3	Each 1 A
----------	----------

Fuses on the control circuit board

Fuse F1	0.8 A slow-blow
Fuse F2	2.0 A slow-blow

2.2 Control circuit board inputs/outputs

2.2.1 Optocoupler inputs (E1-E5), terminals 31 - 40

2.2.2 Analogue input 4-20 mA, terminals 41 -42

2.2.3 Live relay outputs

Outputs VE1 - VN1 to VE3 - VN3

Terminals 8 - 13



NOTE

The connections and designations are to be taken from the respective control cabinet diagrams, according to filter type.

2.2.4 Floating relay outputs

Outputs A1 - A15

Messages 1 - 5
(changeover contact)

Terminals 16 - 30



NOTE

The connections and designations are to be taken from the respective control cabinet diagrams, according to filter type.

3 Operation

3.1 Device functions and control flow

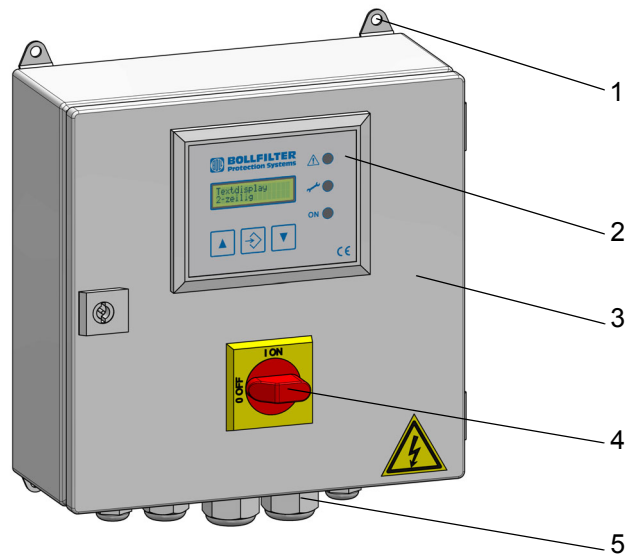

Fig. 3-1 Electrical control box type 2300

- 1 Fastening
- 2 Display and operating elements
- 3 Casing
- 4 Main switch
- 5 Connection

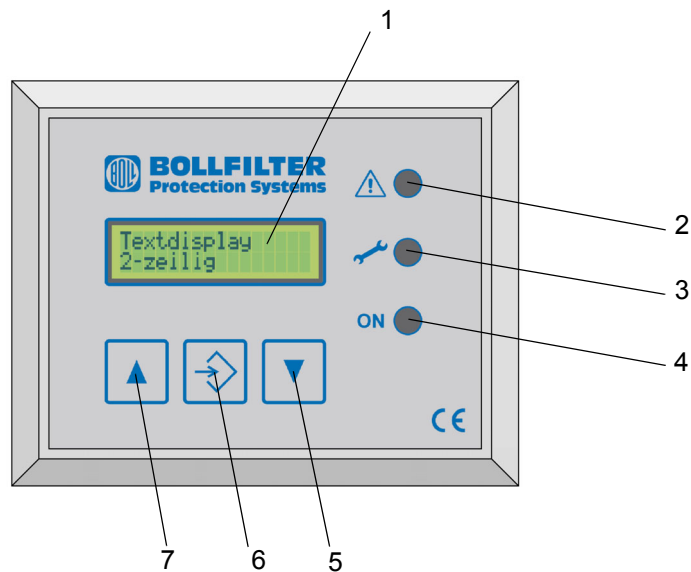

Fig. 3-2 Display and operating elements

- 1 Text output display, 2 lines of 16 characters
- 2 "Alarm" LED (red)
- 3 "Service" LED (yellow)
- 4 "Operation" LED (green)
- 5 Key Q - When pressed, acknowledges the alarm messages
- 6 Key S - When pressed, initiates a manual flush
- 7 Key Z - When pressed, indicates the number of flushes

3.1.1 Main switch operating feedback contact

If the main switch is set to position "On", the contact is closed.

3.1.2 Control voltage monitoring

As soon as the main switch is actuated, the mains voltage is applied and the control box is operating correctly, the "Operation" LED (green) comes on and the relay "control voltage monitoring" is actuated. In the event of loss of the operating voltage or a defective fuse on the control circuit board, no LED comes on and the "control voltage monitoring" relay is no longer actuated.

3.1.3 Motor fault

If the measured motor current exceeds the set setpoint of the P9 parameter, a message is output to the display and a floating signal is output to the relay outputs. The motor and backflushing are immediately switched off. After clearing of the fault, the operator must acknowledge the alarm message by pressing the Q key.

3.1.4 Differential pressure too high, flushing oil treatment cartridge alarm

Signal encoder is a pressure switch contact that is connected to the optocoupler input "Differential pressure indicator DP too high flushing oil treatment". If the message exists for longer than set via parameter P7, an alarm message is output to the display. After clearing of the fault, the operator must acknowledge the alarm message by pressing the Q key.

3.1.5 DP too high backflushing filter ($\Delta P100\%$)

Signal encoder is a pressure switch contact that is connected to the optocoupler input "Differential pressure indicator DP too high backflushing filter". If the message exists for longer than 2 seconds, an alarm message is output to the display and the "Alarm" LED (red) comes on. After clearing of the fault, the operator must acknowledge the alarm message by pressing the Q key.

3.1.6 Operating hours counter

The operating hours counter records the operating hours when the control box is switched on. The operating hours are displayed by multiple pressing of the Z-key (explanation - see section "Z key").

3.1.7 Error memory

The internal error memory records all errors and events including specification of the operating hours. Reading out of the error memory is only allowed for authorised persons.

3.1.8 Differential pressure transmitter 4-20 mA

If a differential pressure transmitter (three-wire) is operated with 4-20 mA, the control box can be changed from a digital differential pressure measurement device (DPS = differential pressure switch) to an analogue differential pressure measurement device (DPT = differential pressure transmitter) (for a detailed setting explanation, see the section "P15 DP-Select").

3.1.9 DPT-Alarm

The alarm message "DPT-Alarm" is output to the display if a differential pressure transmitter (three-wire) is used with 4-20 mA, the parameter P15 "DPT" has been selected and the minimum current of 4 mA cannot be measured. In addition the "Alarm" LED (red) comes on and the alarm output A4, A5 and A6 "General Fault" is activated. After clearing of the fault, the operator must acknowledge the alarm message by pressing the Q key.

3.1.10 Z key (additional functions display)

If key Z (additional functions display) is pressed once, the number of flushes that have been performed is output to the display for 3 seconds.



NOTE

If the Z key is pressed repeatedly, each pressing causes the following additional information to be displayed in the specified sequence:

- Currently measured differential pressure provided a differential pressure transmitter is installed and the parameter P15 "DPT" Select has been set in the control box.
- Operating hours with the control box switched on.
- Currently measured motor current, provided a filter type with a gear motor is installed and has been set in the control box.
- DP-Alarm (flushing frequency monitoring) → on or off
- Actual remaining time "DP1 delayed", if a time delay has been set in the control box "Parameter P16 differential pressure delay time" and the contact of input E1 (terminals 39 + 40, see control cabinet wiring diagrams) has been closed for the flushing differential pressure $\Delta P75\%$.
- Actual remaining time "DP2 delayed", if a time delay has been set in the control box "Parameter P16 differential pressure delay time" and the contact of input E1 (terminals 37 + 38, see control cabinet wiring diagrams) has been closed for the flushing differential pressure $\Delta P100\%$.
- Actual remaining time "P7 cartridge alarm", if a filter type with a flushing oil treatment is installed, in the control box filter type P0 = 4, 8, 14 has been set and the contact of input E3 (terminals 35 + 36, see control cabinet wiring diagrams) for "Differential pressure too high flushing oil treatment cartridge alarm" has been opened.

3.1.11 Multiple flushing

Each flushing command causes the configured number of chambers to be processed.

3.1.12 DP-Alarm (flushing frequency monitoring)

If a "DP flushing" has been activated before the "Time-dependent backflush trigger" period elapses, the message "DP-Alarm" appears on the display and the "Service" LED (yellow) lights up.

3.1.13 Message A4 "Flushing Active"

Output A4 "Flushing active" (terminals 25, 26 and 27, see control cabinet wiring diagrams) is activated as soon as a flushing has been triggered at the filter.

3.1.14 Time delay differential pressure $\Delta P75\%$ and $\Delta P100\%$

The differential pressure signals "DP flushing [75%]" and "DP too high [100%]" of the connected differential pressure measuring device (differential pressure switch [DPS] or differential pressure transmitter [DPT]) can be delayed dependent on the application (for a detailed setting explanation see the section "P16 DP delayed").

3.1.15 Function Remote On/Off (remote switching)

If the contact of input E4 ("Filter Blockage" (terminals 33 and 34, see control cabinet wiring diagrams) has been closed, outputs A13, A14, A15 (terminals 28, 29 and 30, see control cabinet diagrams) are activated and the control box switches to off condition. All outputs and control time meters (e.g. forced flushing time) are reset.

The remote function can only be activated once the message "Flushing active" is no longer present.

Typical representation on the display if remote control is activated:

"6.18/6.19/6.44"	Text display line 1
"Off"	Text display line 2

3.1.16 Initialisation with filter type 6.18/6.19/6.44

Software initialisation is a tool for avoiding errors during commissioning at the customer's site, which is started with the pre-set control box type "6.18/6.19/6.44", in that the gear motor is actuated for 20 seconds with the solenoid valve not activated. During this time a check is performed as to whether a limit switch signal (terminals 31 + 32, see control cabinet diagrams) can be detected.

An error message "P0 filter type" is only output if a limit switch signal is detected because the filter type 6.18/6.19/6.44 is actuated without a limit switch. Then the necessary filter type (with limit switch) must be set (see section "Setting and operation").



NOTE

Initialisation is not started if an operator has previously set the necessary control box type according to the operating instructions.

3.1.17 Limit switch alarm

The alarm message "Limit switch alarm" is output to the display after a so-called position flushing, if the limit switch signal could not be measured at input E5 after 20 seconds. In addition the "Alarm" LED (red) comes on and the alarm output A4, A5 and A6 "General Fault" is activated. After clearing of the fault, the operator must acknowledge the alarm message by pressing the Q key.

3.2 "Operation" mode display

The "Operation" LED (green) comes on after switching on of the mains voltage, if the control box is in the operating level ("Operation" mode).

3.3 Text messages

3.3.1 Text display after switching on

BOLL & KIRCH Company name
 xxxxxxxxxx Program number

After a short time, the configured control box type is output to the second line of the display.

6.18/6.19/6.44	Control box type 0
6.21/6.22/6.23/6.24	Control box type 1
6.60	Control box type 2
6.60.07/6.72.07	Control box type 4
6.61	Control box type 6
6.61.07	Control box type 8
6.62	Control box type 10
6.64	Control box type 12
6.64.07	Control box type 14
6.72	Control box type 16
aquaBoll@6.18.3	Control box type 18 (*)

(*) Control box type 18 has the same function as control box type 0.



NOTE

To simplify operation, control box types 3, 5, 7, 9, 11, 13, 15 and 17 of the preceding control box type 2200 have been removed to simplify operation.

The function "DP-Alarm" (flushing frequency monitoring) is still available and can still be set (see section "P8 DP Alarm").

3.3.2 Text display in "operation" mode

Forced flushing Remaining forced flushing trigger time 00 h 01 min
 00:01

Z - S - Q Key tips

If a flushing process has been initiated, the following messages appear in the first line of the display, depending on the source:

Mains flushing For flushing triggering via "Mains voltage on"

Manual flushing For flushing triggering via key S

Forced flushing For flushing triggering via time-dependent backflush triggering

DP flushing For flushing triggering via backflushing filter differential pressure

Position flushing Flushing triggering if the limit switch signal is lost

If a flushing process has been initiated, the following messages appear in the first line of the display, depending on the source:

Flushing time 3S Remaining flushing time
After-blowing time 3S Remaining after-blowing time



NOTE

3S Means the remaining flushing or after-blowing time equals 3 seconds.

Pressing key z causes the following message to appear in the display:

Flushing number
 xxxxxx Pc Number of flushes

The number of flushes is saved and backed up for protection against mains failure.

3.3.3 Alarm messages



NOTE

- The "Alarm" LED (red) comes on for each alarm message.
- All alarm messages are saved and backed up to protect against mains failure.
- In alternation with the operating messages, the alarm message is output every 2 seconds to the second line of the display.
- Once the Q key is pressed, the alarm messages are deleted, however, only once the source of the alarm has been cleared. If the source of the alarm has not been cleared, the alarm message reappears.

Alarm messages in the display:

Motor fault In the event of a "Motor fault" alarm
DP too high If "High differential pressure Filter 100 %" exists
Cartridge alarm If "Differential pressure too high flushing oil treatment 100 %" exists
Limit switch alarm In the event of loss of the limit switch signal

If flushing frequency monitoring is switched on:

DP-Alarm DP-Alarm triggering of backflushing due to differential pressure 75 % (flushing frequency monitoring)

During differential pressure measurement using the differential pressure transmitter (DPT):

DPT-Alarm In the event of an incorrect 4 mA input signal

3.4 Adjustment and operation

3.4.1 Setting level - parameter selection and view

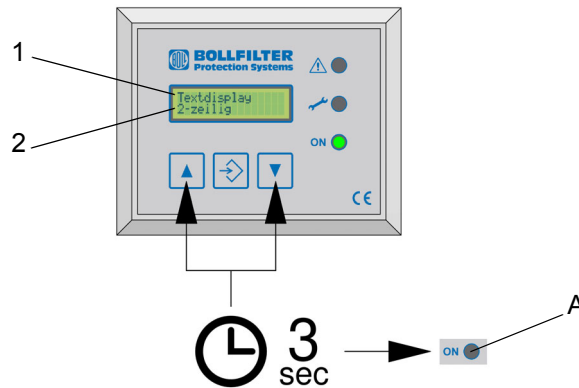

Fig. 3-3 Setting level parameter selection and view

- | | | | |
|---|-----------------|---|--------------------|
| 1 | Parameter | A | Green LED goes off |
| 2 | Parameter value | | |

To access the setting level "Parameter selection and view", the keys ▲ and ▼ are pressed simultaneously until the "Operation" LED (green) goes out (approximately 3 seconds). The first line of the display shows the parameter, the second line the parameter value. Now all parameters can be displayed by repeated pressing of the ▲ or ▼ key.

3.4.2 Setting level - parameter change and storage

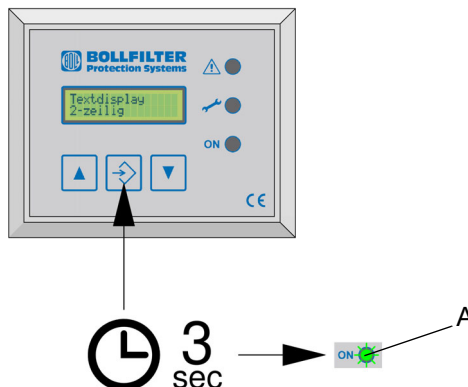

Fig. 3-4 Setting level parameter selection and view

- | | |
|---|-------------------|
| A | Green LED flashes |
|---|-------------------|

To access the setting level "Parameter change and storage", the middle key is pressed until the "Operation" LED (green) flashes (approximately 3 seconds). Now the parameter can be changed by repeated pressing of the ▲ or ▼ key. To save the set value and return to the "Parameter selection and view" setting level, the middle key is pressed until the "Operation" LED (green) goes out (approximately 3 seconds).

3.4.3 Jump back to the operating level

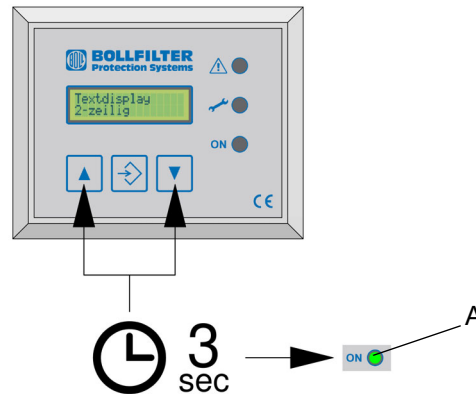

Fig. 3-5 Back to the operating level

A Green LED comes on

To access the operating level, the keys ▲ and ▼ are pressed simultaneously until the "Operation" LED (green) comes on (approximately 3 seconds).

3.5 Parameter list and description

3.5.1 P0 Filter type

Adjustable in single steps	Range 0 - 18
Factory setting	Basic value 0
Text display, line 1	P0 Filter type
Text display, line 2	6.18/6.19/6.44

3.5.2 P1 multiple flushing



NOTE

This parameter is **only** visible for filter type P0 = 6, 8, 10, 12, 14.

Adjustable in single steps	Range 1 - 99 pc.
Factory setting	Basic value 1
Text display, line 1	P1 multiple flushing
Text display, line 2	XXX chambers

3.5.3 P2 time-dependent backflush triggering

Adjustable in hour steps	Range 0 - 59 h
Factory setting	Basic value 2 h
Text display, line 1	P2 Forced flushing
Text display, line 2	XXX hours

3.5.4 P3 time-dependent backflush triggering

Adjustable in minute steps	Range 0 - 59 min
Factory setting	Basic value 0 min
Text display, line 1	P3 Forced flushing
Text display, line 2	XXX minutes

3.5.5 P4 Backflushing time



NOTE

This parameter is **not** visible for filter type P0 = 1.

Adjustable in second steps	Range 5 - 100 s
Factory setting	Basic value 20 s

Text display, line 1	P4 Backflushing time
Text display, line 2	XXX seconds

3.5.6 P5 Filling time



NOTE

This parameter is **not** visible for filter type P0 = 0 and P0 = 1.

Adjustable in 10 second steps	Range 10 - 600 s
Factory setting	Basic value 180 s

Text display, line 1	P5 Filling time
Text display, line 2	XXX seconds

3.5.7 P6 After-blowing time



NOTE

This parameter is **only** visible for filter type P0 = 4, 8, 14.

Adjustable in second steps	Range 5 - 100 s
Factory setting	Basic value 30 s

Text display, line 1	P6 After-blowing time
Text display, line 2	XXX seconds

3.5.8 P7 Delay time cartridge alarm



NOTE

This parameter is **only** visible for filter type P0 = 4, 8, 14.

Adjustable in 10 second steps	Range 10 - 600 s
Factory setting	Basic value 180 s

Text display, line 1	P7 Cartridge alarm
Text display, line 2	XXX seconds

3.5.9 P8 DP-Alarm (flushing frequency monitoring)



NOTE

This parameter can be set for all filter types. For the alarm DP filter types P0 = 3 (6.60 Alarm DP), 5 (6.60.07/6.72.07 Alarm DP), 7 (6.61 Alarm DP), 9 (6.61.07 Alarm DP), 11 (6.62 Alarm DP), 13 (6.64 Alarm DP), 15 (6.64.07 Alarm DP) and 17 (6.72 Alarm DP) of the preceding controlbox type Type 2200 "P8 DP Alarm" must be activated.

Adjustable	Off/on
Factory setting	Basic value Off

Text display, line 1	P8 DP-Alarm
Text display, line 2	Off
or	
Text display, line 2	On

3.5.10 P9 Motor fault

Adjustable in 0.01 A steps	Range 0.10 to 0.99 A
Factory setting	Basic value 0.4 A

Text display, line 1	P9 Motor fault
Text display, line 2	0000 mA



NOTE

The motor fault setting is dependent on the installed and approved standard gear motors 0.09 kW, 0.12 kW or 0.18 kW.

Star connection settings:

0.09 kW - Standard - Gear motor = 0.4 amp
0.12 kW - Standard - Gear motor = 0.65 amp
0.18 kW - Standard - Gear motor = 0.8 amp

3.5.11 P10 Backflushing time



NOTE

This parameter is **only** visible for filter type P0 = 1, type 6.21/6.22/6.23/6.24.

Setting: With ND 32 = 1 / ND 40 = 2 / ND 50 = 3 (ND = nominal diameter)

A particular control time is assigned from a table dependent on the nominal diameter.

For the setting P0.... 1 the parameter is not required.



NOTE

With filter type 6.21/6.22, the backflushing time is generally set to ND 50=3.

Adjustable in single steps	Range 0 to 2
Factory setting	Basic value ND 32 = 1 s
Text display, line 1	P10 ND flushing time
Text display, line 2	ND=XX =XX sec

3.5.12 P11 Language

German, English, French and Spanish are available as operating languages.

Adjustable	D German ES Spanish F French EN English
Factory setting	Basic value EN English
Text display, line 1	P11 Language
Text display, line 2	EN English

3.5.13 P12 Testcode



NOTE

This parameter is visible for all P0 filter types.

The testcode is divided into two areas:

- **Advanced settings:**
In the first area, entry of a testcode grants access to an advanced setting level, in which additional parameters (such as P15, P16 and P17) can be set. (Detailed description see "P15 DP-Select", P16 DP Differential pressure delay time" and "P17 Alarm relay A2, A3, A4")
- **Test mode:**
In the second area, entry of the testcode provides access to a test mode, which is only intended for authorised persons. Additionally, the internal error memory can be read out to a USB stick.

Adjustable in single steps	Range 0 to 9999
Factory setting	Basic value 0

Text display, line 1	P12 Testcode
Text display, line 2	XXXX

3.5.14 P14 Pressure equalisation time



NOTE

This parameter is **only** visible for filter type P0 = 12 and 14.

Adjustable in second steps	Range 0 to 99 s
Factory setting	Basic value 10 s

Text display, line 1	P14 PET
Text display, line 2	XXX seconds

3.5.15 P15 DP-Select "Differential pressure switch or differential pressure transmitter"



NOTE

Entry of **Testcode 44** opens an advanced setting, which allows selection of the differential pressure evaluation between differential pressure switch (DPS = standard) and differential pressure transmitter (DPT = optional).

The advanced setting "P15 DP-Select" is only required if a differential pressure transmitter (output signal: 4-20mA and electrical connection type: three-wire) is used to control the filter.

(Detailed explanation of setting and operation, see Fig. 3.6)

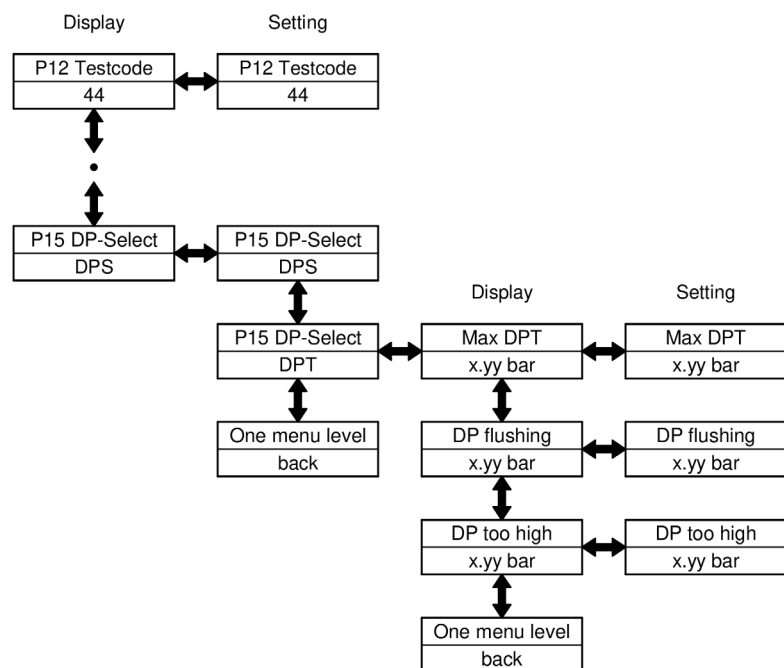

Fig. 3-6 Adjustment and operation

Adjustable	DPS / DPT
Factory setting	Basic value DPS
Text display, line 1	P15 DP-Select
Text display, line 2	DPS
or	
Text display, line 2	DPT

3.5.15.1 "MAX DPT" setting



NOTE

The maximum measurable differential pressure of the installed differential pressure transmitter must be set prior to commissioning.

Adjustable	Range 0.00 - 9.99 bar
Factory setting	Basic value 1.00 bar

Text display, line 1	MAX DPT
Text display, line 2	X.YY bar

3.5.15.2 Setting "DP flushing"



NOTE

The differential pressure signal "Differential pressure flushing ΔP 75%" must be set prior to commissioning.

Adjustable	Range 0.00 - 9.99 bar
Factory setting	Basic value 0.60 bar

Text display, line 1	DP flushing
Text display, line 2	X.YY bar

3.5.15.3 Setting "DP too high"



NOTE

The differential pressure signal "Differential pressure too high ΔP 100%" must be set prior to commissioning.

Adjustable	Range 0.00 - 9.99 bar
Factory setting	Basic value 0.80 bar

Text display, line 1	DP too high
Text display, line 2	X.YY bar

3.5.16 P16 Differential pressure delay time



NOTE

Entry of **Testcode 10** opens an advanced setting, which enables selection of a time delay for the differential pressure signals ΔP 75% and ΔP 100%. (Detailed explanation on setting and operation see Fig. 3.7)

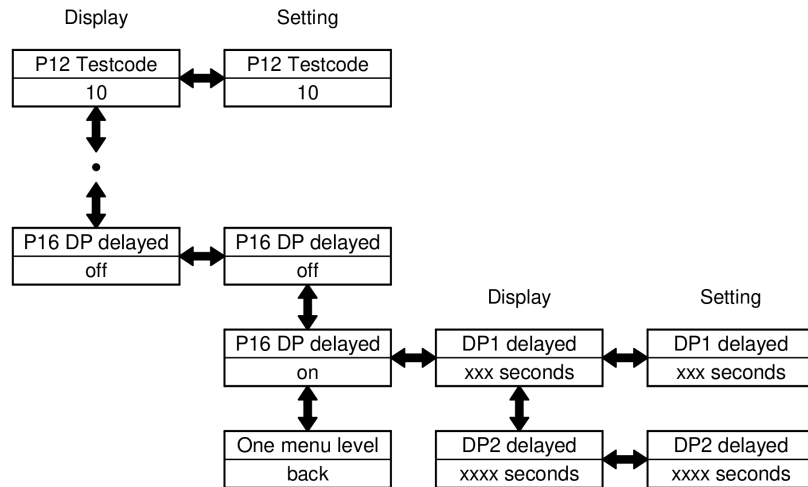

Fig. 3-7 Delay time differential pressure

3.5.16.1 Time delay setting "Differential pressure flushing $\Delta P75\%$ "

Adjustable in second steps	Range 1 - 600 sec
Factory setting	Basic value 20 sec
Text display, line 1	DP1 delayed
Text display, line 2	XXX seconds

3.5.16.2 Time delay setting "Differential pressure too high $\Delta P100\%$ "

Adjustable in second steps	Range 1 - 1800 sec
Factory setting	Basic value 1200 sec
Text display, line 1	DP2 delayed
Text display, line 2	XXX seconds

3.5.17 P17 Alarm relay A2, A3, A4 (configurable alarm outputs)



NOTE

Entry of **Testcode 75** opens an advanced setting that enables configuration of the alarm outputs A2, A3 and A4.

The advanced setting "P17 Alarm Relay A2, A3, A4" is necessary if the customer requires alarm outputs that differ from the standard at the system level (see standard control cabinet diagrams).

(See Fig. 3-8 for detailed explanation of Adjustment and operation)

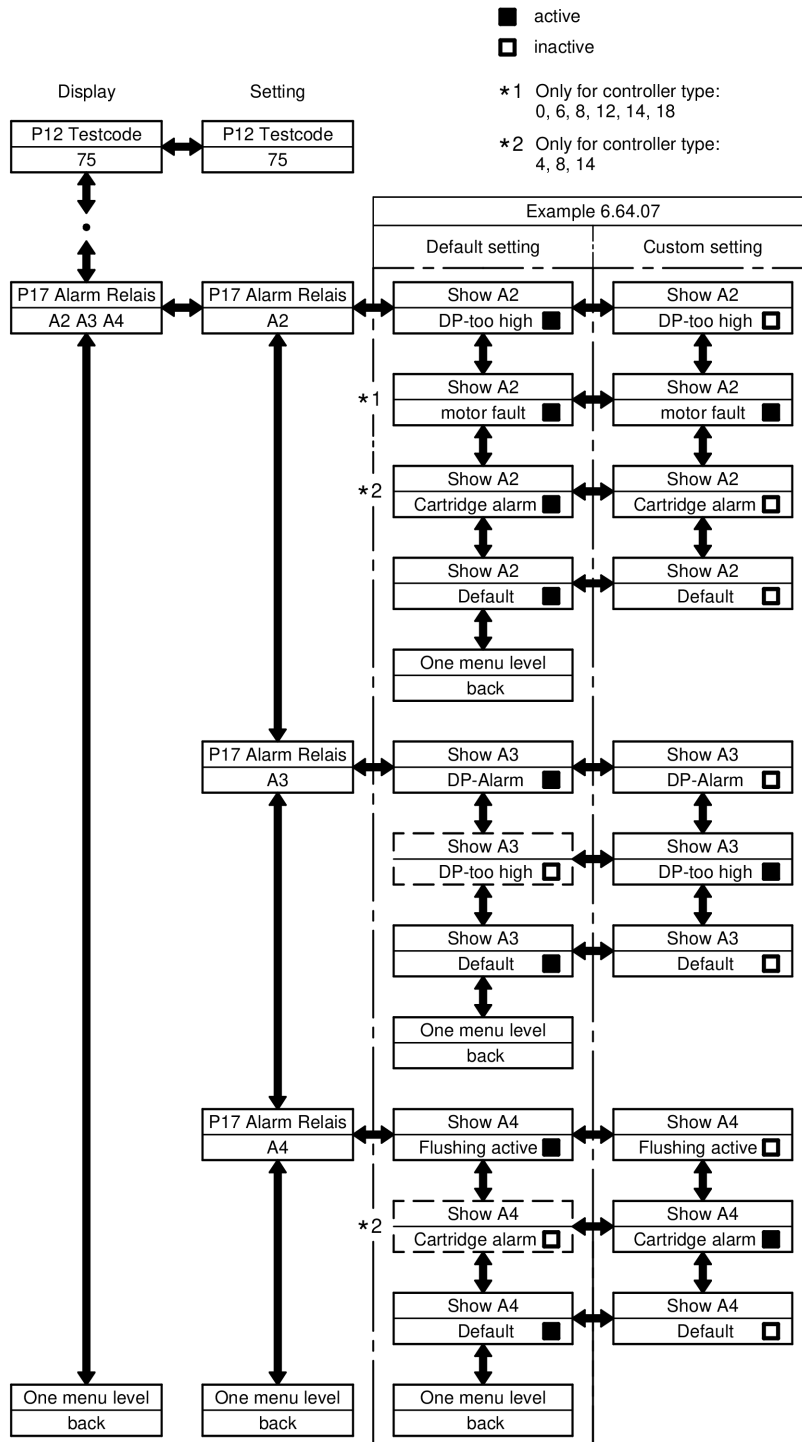

Fig. 3-8 P17 Alarm relay A2, A3, A4

4 Control box description, function and setting values

4.1 Control box of type 6.18 / 6.19 / 6.44 and aquaBoll®6.18.3

Inputs

Pressure switch "DP reached backflushing filter" → 75 %

Pressure switch "DP too high backflushing filter" → 100 %

Customer input → Filter blockage (Remote On/Off)

Outputs

Motor

Flushing valve

Floating contacts

- | | |
|--|----------------------|
| 1) Alarm, "Control voltage monitoring" | Output A1, A2, A3 |
| 2) General fault, comprising:
- Alarm "Maximum differential pressure reached"
and
- Alarm "Motor fault" | Output A4, A5, A6 |
| 3) Alarm "Motor fault" | Output A7, A8, A9 |
| 4) Message "Flushing Active" | Output A10, A11, A12 |
| 5) Message "Filter blockage (Remote On/Off)" | Output A13, A14, A15 |

Functional description 6.18, 6.19, 6.44 and aquaBoll®6.18.3

See the operating instructions for details on filter functioning.

Flushing is triggered via:

- 1) Key S
- 2) The elapsed forced flushing time
- 3) Pressure switch "DP reached backflushing filter"

Additional functions in the DP-Alarm is switched on (flushing frequency monitoring)

If, before the forced flushing time elapses, flushing is triggered via the "DP reached backflushing filter", a DP-Alarm is signalled (flushing frequency alarm) (setting See Section "P8 DP-Alarm").

Parametrisation of the alarm outputs is performed in section "P17 Alarm Relay A2, A3, A4".

Peculiarities

- All alarms are displayed, signalled over floating contacts and saved.
- If the control box is in configuration mode, manual triggering of flushing is not possible.
- If the "Control box type" parameter is changed, the functions are restarted.

4.1.1 Setting values filter type 6.18/6.19/6.44 and aquaBoll®6.18.3

Terminal plan (Standard) Z46600		6.18 / 6.19 / 6.44	aquaBoll®6.18.3
P0	Filter type	0	18
P1	Multiple flushing	/	/
P2	Forced flushing	2h	2h
P3	Forced flushing	0min	0min
P4	Flushing time	20s	20s
P5	Filling time	/	/
P6	After-blowing time	/	/
P7	Delay time Cartridge alarm	/	/
P8	DP-Alarm	Off	Off
P9	Motor fault	0.4A	0.4A
P10	Backflushing time	/	/
P11	Language	D	D
P12	Testcode	/	/
P14	Pressure equalisation time	/	/



NOTE

Setting values can be matched to the respective requirements as necessary.

4.2 Control boxes of type 6.21/6.22/6.23 / 6.24

Inputs 6.21/6.22/6.23 and 6.24

Pressure switch "DP reached backflushing filter" → 75 %

Pressure switch "DP too high backflushing filter" → 100 %

Customer input → Filter blockage (Remote On/Off)

Outputs 6.21/6.22/6.23 and 6.24

Flushing valve

Floating contacts and messages 6.21/6.22/6.23 and 6.24

- | | |
|--|----------------------|
| 1) Alarm, "Control voltage monitoring" | Output A1, A2, A3 |
| 2) Alarm "Maximum DP reached" | Output A4, A5, A6 |
| 3) Message "Flushing Active" | Output A10, A11, A12 |
| 4) Message "Filter blockage (Remote On/Off)" | Output A13, A14, A15 |

Functional description 6.21/6.22/6.23 and 6.24

See the operating instructions for details on filter functioning.

Flushing is triggered via:

- 1) Key S
- 2) The elapsed forced flushing time
- 3) Pressure switch "DP reached backflushing filter"

Additional functions in the DP-Alarm is switched on (flushing frequency monitoring)

If, before the forced flushing time elapses, flushing is triggered via the "DP reached backflushing filter", a DP-Alarm is signalled (flushing frequency alarm) (setting See Section "P8 DP-Alarm").

Parametrisation of the alarm outputs is performed in section "P17 Alarm Relay A2, A3, A4".

Peculiarities

- All alarms are displayed, signalled over floating contacts and saved.
- If the control box is in configuration mode, manual triggering of flushing is not possible.
- If the "Control box type" parameter is changed, the functions are restarted.

4.2.1 Filter type setting values 6.21/6.22

Terminal plan (Standard) Z46611		6.21 / 6.22
P0	Filter type	1
P1	Multiple flushing	/
P2	Forced flushing	Filter unit: < 10 µm = 0.5 h = 10 µm = 1 h > 10 µm = 2 h
P3	Forced flushing	0min
P4	Flushing time	/
P5	Filling time	/
P6	After-blowing time	/
P7	Delay time Cartridge alarm	/
P8	DP-Alarm	Off
P9	Motor fault	/
P10	Backflushing time	3
P11	Language	D
P12	Testcode	/
P14	Pressure equalisation time	/



NOTE

Setting values can be matched to the respective requirements as necessary.

Terminal plan (Standard) Z46601		6.23 / 6.24
P0	Filter type	1
P1	Multiple flushing	/
P2	Forced flushing	2h
P3	Forced flushing	0min
P4	Flushing time	/
P5	Filling time	/
P6	After-blowing time	/
P7	Delay time Cartridge alarm	/
P8	DP-Alarm	Off
P9	Motor fault	/
P10	Backflushing time	1
P11	Language	D
P12	Testcode	/
P14	Pressure equalisation time	/



NOTE

Setting values can be matched to the respective requirements as necessary.

4.3 Control boxes of type 6.60

Inputs 6.60 and 6.60 Alarm DP (flushing frequency monitoring)

Limit switch "Position reached"

Pressure switch "DP reached backflushing filter" → 75 %

Pressure switch "DP too high backflushing filter" → 100 %

Customer input → Filter blockage (Remote On/Off)

Inputs additional with 6.60.07 (flushing oil treatment)

Pressure switch "DP too high Flushing oil treatment" → 100 %

Outputs 6.60 and 6.60 Alarm DP

Flushing valve

Chamber valve

Outputs additional with 6.60.07 and 6.60.07 Alarm DP

After blowing valve

Floating contacts and messages 6.60

- | | |
|---|----------------------|
| 1) Alarm, "Control voltage monitoring" | Output A1, A2, A3 |
| 2) General fault: | Output A4, A5, A6 |
| - Alarm "Maximum differential pressure reached" | |
| - Limit switch alarm | |
| 3) Message "Flushing Active" | Output A10, A11, A12 |
| 4) Message "Filter blockage (Remote On/Off)" | Output A13, A14, A15 |

Floating contacts and messages 6.60 Alarm DP

- | | |
|---|----------------------|
| 1) Alarm, "Control voltage monitoring" | Output A1, A2, A3 |
| 2) General fault: | Output A4, A5, A6 |
| - Alarm "Maximum differential pressure reached" | |
| - Limit switch alarm | |
| 3) Alarm "Backflush triggering by DP" | Output A7, A8, A9 |
| 4) Message "Flushing Active" | Output A10, A11, A12 |
| 5) Message "Filter blockage (Remote On/Off)" | Output A13, A14, A15 |

Floating contacts and messages 6.60.07

- | | |
|---|----------------------|
| 1) Alarm, "Control voltage monitoring" | Output A1, A2, A3 |
| 2) General fault, comprising:
- Alarm "Maximum differential pressure reached"
and
- Alarm "Cartridge"
(DP-Alarm flushing oil treatment)
- Limit switch alarm | Output A4, A5, A6 |
| 3) Message "Flushing Active" | Output A10, A11, A12 |
| 4) Message "Filter blockage (Remote On/Off)" | Output A13, A14, A15 |

Floating contacts and messages 6.60.07 Alarm DP

- | | |
|---|----------------------|
| 1) Alarm, "Control voltage monitoring" | Output A1, A2, A3 |
| 2) General fault, comprising:
- Alarm "Maximum differential pressure reached"
and
- Alarm "Cartridge"
(DP-Alarm flushing oil treatment)
- Limit switch alarm | Output A4, A5, A6 |
| 3) Alarm "Backflush triggering by DP" | Output A7, A8, A9 |
| 4) Message "Flushing Active" | Output A10, A11, A12 |
| 5) Message "Filter blockage (Remote On/Off)" | Output A13, A14, A15 |

Functional description 6.60

See the operating instructions for details on filter functioning.

Flushing is triggered via:

- 1) Application of the mains voltage
- 2) Key S
- 3) The elapsed forced flushing time
- 4) Pressure switch "DP reached backflushing filter"

Additional functions for 6.60 Alarm DP (flushing frequency monitoring)

If, before the forced flushing time elapses, flushing is triggered via the "DP reached backflushing filter", a DP-Alarm is signalled (flushing frequency alarm).

Peculiarities

- All alarms are displayed, signalled over floating contacts and saved.
- If the control box is in configuration mode, manual triggering of flushing is not possible.
- If the "Control box type" parameter is changed, the functions are restarted.

Terminal plan (Standard) Z46602 Z46603		6.60	6.60.07
P0	Filter type	2	4
P1	Multiple flushing	/	/
P2	Forced flushing	Filter unit: < 10 µm = 0.5h = 10 µm = 1h > 10 µm = 2h	
P3	Forced flushing	0min	0min
P4	Flushing time	8s	8s
P5	Filling time	> 5 bar = 240s < 5 bar = 300s	
P6	After-blowing time	/	18s
P7	Delay time Cartridge alarm	/	180s
P8	DP-Alarm	Off	Off
P9	Motor fault	/	/
P10	Backflushing time	/	/
P11	Language	D	D
P12	Testcode	/	/
P14	Pressure equalisation time	/	/



NOTE

Setting values can be matched to the respective requirements as necessary.

4.4 Control boxes of type 6.61

Inputs 6.61 and 6.61 Alarm DP (flushing frequency monitoring)

Limit switch "Position reached"

Pressure switch "DP reached backflushing filter" → 75 %

Pressure switch "DP too high backflushing filter" → 100 %

Customer input → Filter blockage (Remote On/Off)

Inputs additional 6.61.07 and 6.61.07 Alarm DP (flushing oil treatment)

Pressure switch "DP too high Flushing oil treatment" → 100 %

Outputs 6.61 and 6.61 Alarm DP

Flushing valve

Motor

Outputs additional with 6.61.07 and 6.61.07 Alarm DP

After blowing valve

Floating contacts and messages 6.61

- | | |
|--|----------------------|
| 1) Alarm, "Control voltage monitoring" | Output A1, A2, A3 |
| 2) General fault, comprising:
- Alarm "Maximum differential pressure reached"
and
- Alarm "Motor fault"
- Limit switch alarm | Output A4, A5, A6 |
| 3) Message "Flushing Active" | Output A10, A11, A12 |
| 4) Message "Filter blockage (Remote On/Off)" | Output A12, A14, A15 |

Floating contacts and messages 6.61 Alarm DP

- | | |
|--|----------------------|
| 1) Alarm, "Control voltage monitoring" | Output A1, A2, A3 |
| 2) General fault, comprising:
Alarm "Maximum differential pressure reached"
and
Alarm "Motor fault"
- Limit switch alarm | Output A4, A5, A6 |
| 3) Alarm "Backflush triggering by DP" | Output A7, A8, A9 |
| 4) Message "Flushing Active" | Output A10, A11, A12 |
| 5) Message "Filter blockage (Remote On/Off)" | Output A13, A14, A15 |

Floating contacts and messages 6.61.07

- | | |
|---|----------------------|
| 1) Alarm, "Control voltage monitoring" | Output A1, A2, A3 |
| 2) General fault, comprising: <ul style="list-style-type: none">- Alarm "Maximum differential pressure reached",- Alarm "Motor fault" and- Alarm "Cartridge" (DP-Alarm flushing oil treatment)- Limit switch alarm | Output A4, A5, A6 |
| 3) Message "Flushing Active" | Output A10, A11, A12 |
| 4) Message "Filter blockage (Remote On/Off)" | Output A12, A14, A15 |

Floating contacts and messages 6.61.07 Alarm DP

- | | |
|---|----------------------|
| 1) Alarm, "Control voltage monitoring" | Output A1, A2, A3 |
| 2) General fault, comprising: <ul style="list-style-type: none">- Alarm "Maximum differential pressure reached",- Alarm "Motor fault" and- Alarm "Cartridge" (DP-Alarm flushing oil treatment)- Limit switch alarm | Output A4, A5, A6 |
| 3) Alarm "Backflush triggering by DP" | Output A7, A8, A9 |
| 4) Message "Flushing Active" | Output A10, A11, A12 |
| 5) Message "Filter blockage (Remote On/Off)" | Output A12, A14, A15 |

Functional description 6.61

See the operating instructions for details on filter functioning.

Flushing is triggered via:

- 1) Application of the mains voltage
- 2) Key S
- 3) The elapsed forced flushing time
- 4) Pressure switch "DP reached backflushing filter"

Peculiarities

- In the event of flushing triggered by application of the mains voltage and with the limit switch open, flushing starts directly with the flushing valve.
- If the control box is in configuration mode, manual triggering of flushing is not possible.
- If the "Control box type" parameter is changed, the functions are restarted.

Terminal plan (Standard) Z46604 Z46605		6.61	6.61.07
P0	Filter type	6	8
P1	Multiple flushing	1	1
P2	Forced flushing	Filter unit: < 10 µm = 0.5h = 10 µm = 1h > 10 µm = 2h	
P3	Forced flushing	0min	0min
P4	Flushing time	8s	8s
P5	Filling time	Up to DN150 - 120s From DN200 - 150s	
P6	After-blowing time	/	18s
P7	Delay time Cartridge alarm	/	180s
P8	DP-Alarm	Off	Off
P9	Motor fault	0.4A	0.4A
P10	Backflushing time	/	/
P11	Language	D	D
P12	Testcode	/	/
P14	Pressure equalisation time	/	/



NOTE

Setting values can be matched to the respective requirements as necessary.

4.5 Control boxes of type 6.62

Inputs 6.62

Limit switch "Position reached"

Pressure switch "DP reached backflushing filter" → 75 %

Pressure switch "DP too high backflushing filter" → 100 %

Customer input → Filter blockage (Remote On/Off)

Outputs 6.62

Flushing valve

Chamber valve clocked

Floating contacts and messages 6.62

- | | |
|--|----------------------|
| 1) Alarm, "Control voltage monitoring" | Output A1, A2, A3 |
| 2) General fault:
- Alarm "Maximum differential pressure reached"
- Limit switch alarm | Output A4, A5, A6 |
| 3) Message "Flushing Active" | Output A10, A11, A12 |
| 4) Message "Filter blockage (Remote On/Off)" | Output A12, A14, A15 |

Floating contacts and messages 6.62 Alarm DP (flushing frequency monitoring)

- | | |
|--|----------------------|
| 1) Alarm, "Control voltage monitoring" | Output A1, A2, A3 |
| 2) General fault:
- Alarm "Maximum differential pressure reached"
- Limit switch alarm | Output A4, A5, A6 |
| 3) Alarm "Backflush triggering by DP" | Output A7, A8, A9 |
| 4) Message "Flushing Active" | Output A10, A11, A12 |
| 5) Message "Filter blockage (Remote On/Off)" | Output A12, A14, A15 |

Functional description 6.62

See the operating instructions for details on filter functioning.

Flushing is triggered via:

- 1) Application of the mains voltage
- 2) Key S
- 3) The elapsed forced flushing time
- 4) Pressure switch "DP reached backflushing filter"

Peculiarities

- In the event of flushing triggered by application of the mains voltage and with the limit switch open, flushing starts directly with the flushing valve.
- If the control box is in configuration mode, manual triggering of flushing is not possible.
- If the "Control box type" parameter is changed, the functions are restarted.

Terminal plan (Standard) Z46606		6.62
P0	Filter type	10
P1	Multiple flushing	1
P2	Forced flushing	Filter unit: < 10 µm = 0.5 h = 10 µm = 1 h > 10 µm = 2 h
P3	Forced flushing	0min
P4	Flushing time	8s
P5	Filling time	> 5 bar = 240s < 5 bar = 300s
P6	After-blowing time	/
P7	Delay time Cartridge alarm	/
P8	DP-Alarm	Off
P9	Motor fault	/
P10	Backflushing time	/
P11	Language	D
P12	Testcode	/
P14	Pressure equalisation time	/



NOTE

Setting values can be matched to the respective requirements as necessary.

4.6 Control boxes of type 6.64

Inputs 6.64 and 6.64 Alarm DP (flushing frequency monitoring)

Limit switch "Position reached"

Pressure switch "DP reached backflushing filter" → 75 %

Pressure switch "DP too high backflushing filter" → 100 %

Customer input → Filter blockage (Remote On/Off)

Inputs additional 6.64.07 and 6.64.07 Alarm DP (flushing oil treatment)

Pressure switch "DP too high Flushing oil treatment" → 100 %

Outputs 6.64 and 6.64 Alarm DP

Flushing valve

Motor

Relief valve

Outputs additional with 6.64.07 and 6.64.07 Alarm DP

After blowing valve

Floating contacts and messages 6.64

- | | |
|--|----------------------|
| 1) Alarm, "Control voltage monitoring" | Output A1, A2, A3 |
| 2) General fault, comprising:
- Alarm "Maximum differential pressure reached"
and
- Alarm "Motor fault"
- Limit switch alarm | Output A4, A5, A6 |
| 3) Message "Flushing Active" | Output A10, A11, A12 |
| 4) Message "Filter blockage (Remote On/Off)" | Output A12, A14, A15 |

Floating contacts and messages 6.64 Alarm DP

- | | |
|--|----------------------|
| 1) Alarm, "Control voltage monitoring" | Output A1, A2, A3 |
| 2) General fault, comprising:
- Alarm "Maximum differential pressure reached"
and
- Alarm "Motor fault"
- Limit switch alarm | Output A4, A5, A6 |
| 3) Alarm "Backflush triggering by DP" | Output A7, A8, A9 |
| 4) Message "Flushing Active" | Output A10, A11, A12 |
| 5) Message "Filter blockage (Remote On/Off)" | Output A12, A14, A15 |

Floating contacts and messages 6.64.07

- | | |
|---|----------------------|
| 1) Alarm, "Control voltage monitoring" | Output A1, A2, A3 |
| 2) General fault, comprising:
- Alarm "Maximum differential pressure reached",
- Alarm "Motor fault" and
- Alarm "Cartridge" (DP-Alarm flushing oil treatment)
- Limit switch alarm | Output A4, A5, A6 |
| 3) Message "Flushing Active" | Output A10, A11, A12 |
| 4) Message "Filter blockage (Remote On/Off)" | Output A12, A14, A15 |

Floating contacts and messages 6.64.07 Alarm DP

- | | |
|---|----------------------|
| 1) Alarm, "Control voltage monitoring" | Output A1, A2, A3 |
| 2) General fault, comprising:
- Alarm "Maximum differential pressure reached",
- Alarm "Motor fault" and
- Alarm "Cartridge" (DP-Alarm flushing oil treatment)
- Limit switch alarm | Output A4, A5, A6 |
| 3) Alarm "Backflush triggering by DP" | Output A7, A8, A9 |
| 4) Message "Flushing Active" | Output A10, A11, A12 |
| 5) Message "Filter blockage (Remote On/Off)" | Output A12, A14, A15 |

Functional description 6.64

See the operating instructions for details on filter functioning.

Flushing is triggered via:

- 1) Application of the mains voltage
- 2) Key S
- 3) The elapsed forced flushing time
- 4) Pressure switch "DP reached backflushing filter"

Peculiarities

- In the event of flushing triggered by application of the mains voltage and with the limit switch open, a flushing process starts with the flushing valve after the pressure equalisation time has elapsed.
- If the control box is in configuration mode, manual triggering of flushing is not possible.
- If the "Control box type" parameter is changed, the functions are restarted.

Terminal plan (Standard) Z46607 Z46608		6.64	6.64.07
P0	Filter type	12	14
P1	Multiple flushing	1	1
P2	Forced flushing	Filter unit: < 10 µm = 0.5h = 10 µm = 1h > 10 µm = 2h	
P3	Forced flushing	0min	0min
P4	Flushing time	8s	8s
P5	Filling time	Up to DN150 - 180s From DN200 - 360s	
P6	After-blowing time	/	18s
P7	Delay time Cartridge alarm	/	180s
P8	DP-Alarm	Off	Off
P9	Motor fault	0.4A	0.4A
P10	Backflushing time	/	/
P11	Language	D	D
P12	Testcode	/	/
P14	Pressure equalisation time	Up to DN150 - 1s From DN200 - 10s	



NOTE

Setting values can be matched to the respective requirements as necessary.

4.7 Control boxes of type 6.72

Inputs 6.72 and 6.72 Alarm DP (flushing frequency monitoring)

Limit switch "Position reached"

Pressure switch "DP reached backflushing filter" → 75 %

Pressure switch "DP too high backflushing filter" → 100 %

Customer input → Filter blockage (Remote On/Off)

Inputs additional with 6.72.07 (flushing oil treatment)

Pressure switch "DP too high Flushing oil treatment" → 100 %

Outputs 6.72 and 6.72 Alarm DP

Flushing valve

Chamber valve

Outputs additional with 6.72.07 and 6.72.07 Alarm DP

After blowing valve

Floating contacts and messages 6.72

- | | |
|---|----------------------|
| 1) Alarm, "Control voltage monitoring" | Output A1, A2, A3 |
| 2) General fault: | Output A4, A5, A6 |
| - Alarm "Maximum differential pressure reached" | |
| - Limit switch alarm | |
| 3) Message "Flushing Active" | Output A10, A11, A12 |
| 4) Message "Filter blockage (Remote On/Off)" | Output A12, A14, A15 |

Floating contacts and messages 6.72 Alarm DP

- | | |
|---|----------------------|
| 1) Alarm, "Control voltage monitoring" | Output A1, A2, A3 |
| 2) General fault: | Output A4, A5, A6 |
| - Alarm "Maximum differential pressure reached" | |
| - Limit switch alarm | |
| 3) Alarm "Backflush triggering by DP" | Output A7, A8, A9 |
| 4) Message "Flushing Active" | Output A10, A11, A12 |
| 5) Message "Filter blockage (Remote On/Off)" | Output A12, A14, A15 |

Floating contacts and messages 6.72.07

- | | |
|--|----------------------|
| 1) Alarm, "Control voltage monitoring" | Output A1, A2, A3 |
| 2) General fault, comprising: <ul style="list-style-type: none">- Alarm "Maximum differential pressure reached" and- Alarm "Cartridge" (DP-Alarm flushing oil treatment)- Limit switch alarm | Output A4, A5, A6 |
| 3) Message "Flushing Active" | Output A10, A11, A12 |
| 4) Message "Filter blockage (Remote On/Off)" | Output A12, A14, A15 |

Floating contacts and messages 6.72.07 Alarm DP

- | | |
|--|----------------------|
| 1) Alarm, "Control voltage monitoring" | Output A1, A2, A3 |
| 2) General fault, comprising: <ul style="list-style-type: none">- Alarm "Maximum differential pressure reached" and- Alarm "Cartridge" (DP-Alarm flushing oil treatment)- Limit switch alarm | Output A4, A5, A6 |
| 3) Alarm "Backflush triggering by DP" | Output A7, A8, A9 |
| 4) Message "Flushing Active" | Output A10, A11, A12 |
| 5) Message "Filter blockage (Remote On/Off)" | Output A12, A14, A15 |

Functional description 6.72

See the operating instructions for details on filter functioning.

Flushing is triggered via:

- 1) Application of the mains voltage
- 2) Key S
- 3) The elapsed forced flushing time
- 4) Pressure switch "DP reached backflushing filter"

Additional functions for 6.72 Alarm DP (flushing frequency monitoring)

If, before the forced flushing time elapses, flushing is triggered via the "DP reached backflushing filter", a DP-Alarm is signalled (flushing frequency alarm).

Peculiarities

- All alarms are displayed, signalled over floating contacts and saved.
- If the control box is in configuration mode, manual triggering of flushing is not possible.
- If the "Control box type" parameter is changed, the functions are restarted.

Terminal plan (Standard) Z46609 Z46610		6.72	6.72.07
P0	Filter type	16	4
P1	Multiple flushing	/	/
P2	Forced flushing	Filter unit: < 10 µm = 0.5h = 10 µm = 1h > 10 µm = 2h	
P3	Forced flushing	0min	0min
P4	Flushing time	8s	8s
P5	Filling time	DN40: > 5 bar = 120s < 5 bar = 200s DN65: > 5 bar = 200s < 5 bar = 320s DN80: > 5 bar = 240s < 5 bar = 400s	
P6	After-blowing time	/	18s
P7	Delay time Cartridge alarm	/	180s
P8	DP-Alarm	Off	Off
P9	Motor fault	0.4A	0.4A
P10	Backflushing time	/	/
P11	Language	D	D
P12	Testcode	/	/
P14	Pressure equalisation time	/	/



NOTE

Setting values can be matched to the respective requirements as necessary.

5 Remediating faults



NOTE

In case of any faults or repairs which are not listed here, contact the BOLL & KIRCH customer services department.

5.1 Trouble shooting

Fault	Possible cause	Rectification
Actuation of the automatic filter does not occur	Faulty wiring	Check the wiring, power supply and transformer configuration according to the control box diagram
	Incorrect control box type set	Set the control box type according to the operating instructions
Display keys do not operate	Key membrane damaged	Change Display -A1
	Connecting cable between PCB and the display is loose	Remake the plug connection
	Connecting cable between PCB and display defective	Change connecting cable
Display does not work	Power supply faulty	Check power supply and in particular check for the correct setting of the primary voltage at the transformer - T1
	Connecting cable between PCB and the display is loose	Remake the plug connection
	Connecting cable between PCB and display defective	Change connecting cable
	Display -A1 defective	Change Display -A1
	Transformer -T1 defective	Change transformer -T1
	PCB -A2 defective	Change PCB -A2
	Fuse(s) F1 and/or F3 (1 amp) defective	Change fuse(s)
Gear motor does not turn + alarm message "Motor fault"	Incorrect control box type set	Please set the control box type according to the operating instructions
	Fuse F2 (1 amp) defective	Change fuse
	Filter operating fault (gear motor etc.)	See automatic filter operating instructions
	Faulty wiring	Check the wiring of the gear motor
Alarm message "Limit switch alarm"	Limit switch signal missing	Check the setting and wiring of the limit switch
	Limit switch defective	See automatic filter operating instructions

Fault	Possible cause	Rectification
Alarm message "P0 Filter type" after initialisation of filter type 6.18/6.19/6.44	During the "Filter type 6.18/6.19/6.44" initialisation, it was identified that a limit switch signal (terminals 31+32, see control cabinet wiring diagrams) was present and consequently the incorrect filter type had been set. (Background: control box type 0 set to operation without limit switch)	Set the control box type according to the operating instructions
Differential pressure is not be processed	Differential pressure indicator defective	Check/change differential pressure indicator
	Parameter P16 differential pressure delay time set	See explanations about the differential pressure time delay, P16 parameter setting and additional functions display (Z key) in the operating instructions
Solenoid valve including coil does not function	Incorrect control box type set	Set the control box type according to the operating instructions
	Incorrect control / valve voltage set	Equalise the coil voltage with the set secondary voltage set at the transformer and correct as necessary
	2 amp fuse F2 on the PCB - A2 defective	Change fuse
	Solenoid valve and/or coil defective	Change solenoid valve and/or coil
Display "off"	Remote On/Off function (remote switching) has been activated by closing the E4 input (terminals 33+34, see control cabinet wiring diagrams)	This function can be deactivated by opening the contact of the input E4